

UNFINISHED GLANDS

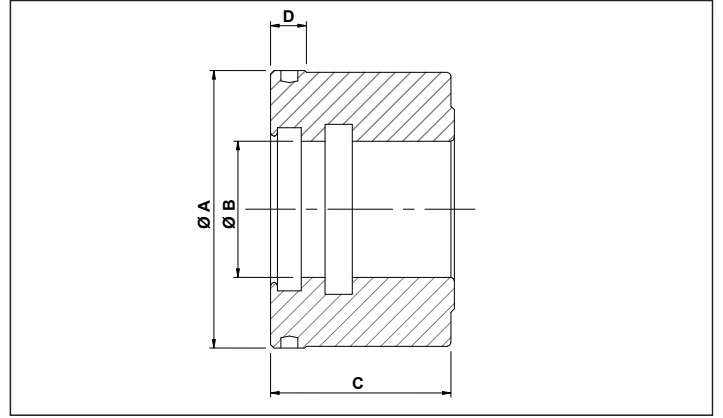

STANDARD GLAND SG	OUTSIDE DIAMETER Ø A 54	ROD DIAMETER Ø B 20	PARTIAL LENGTH 57	UNFINISHED GLAND UF
----------------------	----------------------------	------------------------	----------------------	------------------------

PART NUMBER	Ø A	Ø B	C	D
SG542057UF	54	20	65	8
SG542257UF	54	22	65	8
SG542557UF	54	25	65	8
SG542857UF	54	28	65	8
SG742565UF	74	25	75	10
SG742865UF	74	28	75	10
SG743065UF	74	30	75	10
SG743265UF	74	32	75	10
SG743565UF	74	35	75	10
SG744065UF	74	40	75	10
SG943075UF	94	30	85	10
SG943575UF	94	35	85	10
SG944075UF	94	40	85	10
SG944575UF	94	45	85	10
SG945075UF	94	50	85	10
SG1144095UF	114	40	107	12
SG1144595UF	114	45	107	12
SG1145095UF	114	50	107	12
SG1146095UF	114	60	107	12

UNFINISHED GLANDS COME COMPLETE WITH SEALS FOR THE ROD

MATERIAL : HYDRAULIC CAST IRON GRADE G25
 MAXIMUM WORKING PRESSURE 250 BAR